



Paper Type: Original Article

## The Role of Mechanical Ventilation Systems and their Applications in Contemporary Engineering Practices

Aniekan Essienubong Ikpe<sup>1</sup>, Imoh Ime Ekanem<sup>1,\*</sup>, Victor Etok Udoh<sup>2</sup>

<sup>1</sup> Department of Mechanical Engineering Technology, Akwa Ibom State Polytechnic, Ikot Osurua, Ikot Ekpene, Nigeria; aniekan.ikpe@akwaibompoly.edu.ng; imoh.ekanem@akwaibompoly.edu.ng.

<sup>2</sup> Department of Welding and Fabrication Engineering, Akwa Ibom State Polytechnic, Ikot Osurua, Ikot Ekpene, Nigeria; victor.udoh@akwaibompoly.edu.ng.

### Citation:

<i>Received: 19 September 2024</i>	Ikpe, A. E., Ekanem, I. I., & Udoh, V. E. (2024). The role of mechanical ventilation systems and their applications in contemporary engineering practices. <i>Optimality</i> , 1 (2), 262-275.
<i>Revised: 24 October 2024</i>	
<i>Accepted: 29 November 2024</i>	

### Abstract

Mechanical Ventilation Systems (MVSs) are essential for preserving indoor air quality and thermal comfort in structures. The insufficient awareness of the underlying principles of MVSs in traditional engineering procedures has resulted in inefficient design and operation of these systems. This has led to subpar indoor air quality, discomfort, and energy inefficiency in structures. This study examined the fundamental principles of MVSs and their implementation in engineering techniques. The methodology comprised a thorough examination of the available literature regarding MVSs and the fundamental principles that dictate their design and operation. This included technical reports, relevant datasets, and industry standards regarding ventilation system design and installation. The research included the examination of structures equipped with MVSs to evaluate their effectiveness in real-world situations. The results of this study indicated that although traditional engineering procedures establish a robust basis for the design and installation of MVSs, numerous areas require enhancement. A significant result is that the design and installation of ventilation systems frequently neglect the individual requirements and usage patterns of building occupants. This may result in inadequate ventilation rates and inadequate indoor air quality. Furthermore, the maintenance and operation of ventilation systems are frequently neglected, resulting in diminished system efficiency and heightened energy usage. The research also indicated that the implementation of sophisticated technologies, including smart ventilation controls and energy recovery systems, can provide optimal solutions to enhance the performance of MVSs. The engineering community must prioritize established standards and training in MVSs to guarantee sustainable and healthy indoor environments.

**Keywords:** Air quality, Mechanical ventilation systems, Thermal comfort, Healthy indoor environments.

## 1 | Introduction

Mechanical Ventilation Systems (MVSs) are designed to provide a controlled flow of fresh air into a space while removing stale air and pollutants, ensuring a healthy and comfortable indoor environment for occupants [1]. These systems help to regulate indoor air quality, control humidity levels, and prevent the build-up of pollutants. Fundamental principles of MVSs play a crucial role in conventional engineering practice,

✉ Corresponding Author: aniekan.ikpe@akwaibompoly.edu.ng



Licensee System Analytics. This article is an open access article distributed under the terms and conditions of the Creative Commons Attribution (CC BY) license (<http://creativecommons.org/licenses/by/4.0>).

particularly in the design and operation of buildings and industrial facilities. MVSSs also help to reduce the risk of indoor air pollution, which can lead to respiratory problems and other health issues [2]. Some of the fundamental principles of MVSSs are highlighted as follows:

- I. The concept of air exchange: air exchange refers to the process of replacing stale indoor air with fresh outdoor air to maintain indoor air quality. This is achieved through the use of fans and ductwork to circulate air throughout a building, ensuring that pollutants and contaminants are effectively removed. Proper air exchange rates are essential to prevent the buildup of harmful gases, odors, and particulate matter in indoor spaces [3], [4].
- II. The concept of ventilation efficiency: ventilation efficiency refers to the ability of a ventilation system to effectively distribute fresh air throughout a space while minimizing energy consumption. This can be achieved through the use of energy-efficient fans, ductwork design, and control systems that optimize airflow based on occupancy levels and indoor air quality measurements. By maximizing ventilation efficiency, engineers can ensure that buildings are adequately ventilated while minimizing energy costs and environmental impact [5].
- III. The concept of air distribution and filtration: proper air distribution involves the strategic placement of supply and return air vents to ensure even airflow throughout a space, while air filtration involves the use of filters to remove airborne particles and contaminants. These concepts are essential for maintaining indoor air quality and preventing the spread of pollutants and allergens within a building [6].

The fundamental principles of MVSSs are essential for ensuring the health, comfort, and safety of building occupants. By understanding and applying these principles in conventional engineering practice, engineers can design and operate ventilation systems that effectively control indoor air quality while minimizing energy consumption. As the importance of indoor air quality continues to grow, engineers must prioritize the principles of MVSSs in their design and operation practices.

## 2 | Trends in Principles of Mechanical Ventilation Systems

Recent trends in the principles of MVSSs in conventional engineering practice have experienced a shift towards more energy-efficient and sustainable solutions. With the increasing focus on environmental sustainability and energy conservation, advanced technologies and innovative design strategies are being incorporated to optimize the performance of ventilation systems [7]. Some of the key recent trends in MVSSs are:

- I. The integration of smart controls and automation: by utilizing sensors and advanced control algorithms, engineers are able to dynamically adjust ventilation rates based on real-time occupancy levels and indoor air quality parameters. This not only ensures optimal ventilation performance but also helps reduce energy consumption by avoiding over-ventilation in unoccupied spaces [8].
- II. The use of energy recovery technologies: heat exchangers and heat recovery ventilators are being increasingly incorporated into ventilation systems to capture and reuse the energy from exhaust air streams. This not only helps reduce the overall energy consumption of the building but also improves indoor air quality by pre-conditioning the incoming fresh air [9], [10].
- III. The growing emphasis on the integration of natural ventilation strategies in MVSSs: by incorporating operable windows, louvers, and other passive ventilation elements, engineers are able to enhance the overall ventilation performance of the building while reducing the reliance on mechanical systems. This not only helps reduce energy consumption but also provides occupants with a more comfortable and healthy indoor environment [11].

By incorporating smart controls, energy recovery technologies, and natural ventilation strategies, engineers are able to optimize the performance of ventilation systems while reducing the environmental impact of buildings. As the industry continues to evolve, manufacturers need to stay abreast of these trends and incorporate them into their design practices to create more efficient and sustainable buildings.

### 3 | Technological Advancements in Mechanical Ventilation Systems

Technological advancements have played a crucial role in the development of MVSs in conventional engineering practice. These systems have undergone significant improvements over the years, leading to more efficient and reliable ventilation solutions for various applications. The key milestones in the evolution of MVSs are:

- I. The introduction of computerized control systems: these systems allow for precise control of ventilation parameters such as airflow rate, temperature, and humidity, leading to improved comfort and energy efficiency. Computerized control systems also enable remote monitoring and diagnostics, making it easier to identify and address issues with the ventilation system [12].
- II. The development of energy-efficient ventilation technologies: advances in fan design, motor efficiency, and airflow optimization have led to significant reductions in energy consumption while maintaining or even improving ventilation performance. Energy-efficient ventilation systems not only help reduce operating costs but also contribute to sustainability efforts by lowering carbon emissions [13].
- III. The integration of smart sensors and Internet of Things (IoT's) technology: these sensors can monitor indoor air quality in real time and adjust ventilation parameters accordingly to ensure optimal air quality and comfort. IoT's technology also enables predictive maintenance, allowing for timely repairs and replacements to prevent system failures and downtime [14], [15].

Technological advancements have been key drivers in the evolution of MVSs in conventional engineering practice. Computerized control systems, energy-efficient technologies, and smart sensors have all contributed to the development of more efficient and reliable ventilation solutions. As technology continues to advance, we can expect further improvements in MVSs, leading to even greater comfort, energy efficiency, and sustainability in buildings and other applications.

### 4 | Principles of Mechanical Ventilation Systems

MVSs play a crucial role in maintaining indoor air quality and comfort in buildings. These systems work by using fans to circulate air throughout a space, either by bringing in fresh outdoor air or by recirculating and filtering indoor air. In conventional engineering practice, several key principles govern the operation of MVSs. Some of the fundamental principles of MVSs are highlighted below:

- I. The concept of air exchange: this refers to the process of replacing stale indoor air with fresh outdoor air to maintain a healthy and comfortable indoor environment. By continuously circulating air, MVSs help to remove pollutants, odors and excess moisture from the air, improving overall air quality [16].
- II. The control of airflow: the amount of air that is circulated through space is typically controlled by adjusting the speed of the fans or dampers in the system. By carefully regulating airflow, MVSs can ensure that indoor air quality is maintained at optimal levels while also minimizing energy consumption [17].
- III. MVSs also rely on filtration to remove contaminants from the air: filters are typically installed in ventilation systems to capture dust, pollen, and other particles that can affect indoor air quality. By regularly replacing or cleaning filters, MVSs can effectively remove pollutants and allergens from the air, creating a healthier indoor environment [18].

The operation of MVSs in conventional engineering practice is based on the principles of air exchange, airflow control, and filtration. By following these principles, MVSs can effectively maintain indoor air quality and comfort in buildings. As such, engineers and building owners need to understand and implement these principles in order to ensure the proper functioning of MVSs.

## 5 | Components of Mechanical Ventilation Systems

MVSs are essential components in buildings to ensure proper air circulation and maintain indoor air quality. These systems consist of the following components, which work together to provide a comfortable and healthy environment for occupants.

- I. The fan: the fan is responsible for drawing in fresh air from the outside and distributing it throughout the building. It plays a crucial role in ensuring proper air circulation and preventing the build-up of stale air and pollutants. Without a functioning fan, the ventilation system would not be able to effectively remove indoor air contaminants and maintain a healthy indoor environment [19].
- II. The air filter: air filters are designed to capture dust, pollen, and other airborne particles that can affect indoor air quality. By trapping these contaminants, air filters help to improve the overall air quality in the building and protect occupants from respiratory issues. Regular maintenance and replacement of air filters are essential to ensure the effectiveness of the ventilation system [20].
- III. Ductwork: Ductwork is responsible for distributing the conditioned air throughout the building and removing stale air. Properly designed and installed ductwork is crucial for ensuring efficient air distribution and maintaining consistent indoor air quality. Leaks or blockages in the ductwork can lead to poor ventilation and compromised indoor air quality [21].
- IV. The control system: this is a critical component of a MVS. The control system regulates the operation of the ventilation system based on factors such as indoor air quality, occupancy levels, and outdoor air conditions. By adjusting the ventilation rate and airflow, the control system helps to optimize energy efficiency and maintain a comfortable indoor environment. Advanced control systems can also provide real-time monitoring and feedback to ensure optimal performance of the ventilation system [22].

MVSs consist of various components that work together to provide a healthy and comfortable indoor environment. The fan, air filter, ductwork, and control system are all essential components that play a crucial role in ensuring proper air circulation and maintaining indoor air quality. Regular maintenance and proper operation of these components are essential to ensure the effectiveness of the ventilation system. By understanding the highlights of these components, building owners and facility managers can make informed decisions to improve indoor air quality and occupant comfort.

## 6 | Design Considerations for Mechanical Ventilation Systems

In conventional engineering practice, the design of MVSs requires careful consideration of various factors to ensure optimal performance and energy efficiency. These include the following:

- I. Determine the ventilation requirements of the building: this involves calculating the required air exchange rate based on factors such as the size of the space, the number of occupants, and the activities taking place in the building. It is important to ensure that the ventilation system is capable of providing adequate fresh air to maintain indoor air quality and prevent the build-up of pollutants [23], [24].
- II. Select the appropriate type of ventilation system for the building: there are several types of MVSs available, including exhaust ventilation, supply ventilation, and balanced ventilation. The choice of system will depend on factors such as the building layout, the climate, and the desired level of control over indoor air quality [25].
- III. Design the layout of the system: this involves determining the location of air intake and exhaust vents, as well as the routing of ductwork to ensure efficient air distribution throughout the building. It is important to consider factors such as the pressure drop in the ductwork, the noise levels of the system, and the accessibility for maintenance and repairs [26].
- IV. Selection of appropriate equipment: this includes choosing the right size and type of fans, filters, and controls to ensure optimal performance and energy efficiency. It is important to consider factors such as fan efficiency, filter efficiency, and the control strategy to minimize energy consumption while maintaining indoor air quality [27].

- V. Provisions for monitoring and maintenance: this involves installing sensors to monitor indoor air quality and system performance, as well as implementing a regular maintenance schedule to ensure the system operates efficiently and effectively. It is important to conduct regular inspections and testing of the system to identify and address any issues before they become major problems [28].

The design of MVSS in conventional engineering practice requires careful consideration of various factors to ensure optimal performance and energy efficiency. By following the aforementioned approach to design considerations, engineers can create ventilation systems that provide adequate fresh air, maintain indoor air quality, and ensure the comfort of building occupants.

## 7 | Design Factors that Affect the Performance of Mechanical Ventilation Systems

MVSS play a crucial role in maintaining indoor air quality and thermal comfort in buildings. The performance and effectiveness of these systems are influenced by a variety of design factors that must be carefully considered during the planning and implementation stages. In conventional engineering practice, the following list of design factors can significantly impact the overall performance of MVSS:

- I. System capacity: the first step in designing a MVSS is to determine the required capacity based on the size and occupancy of the building. Oversized systems can lead to energy wastage, while undersized systems may not provide adequate ventilation [29].
- II. Air distribution: proper air distribution is essential for ensuring that fresh air is effectively delivered to all areas of the building. Factors such as duct layout, diffuser placement, and airflow patterns must be carefully considered to prevent stagnant zones and ensure uniform ventilation [30].
- III. Filtration: the quality of indoor air is heavily dependent on the effectiveness of filtration in the ventilation system. High-efficiency filters can help remove pollutants and allergens, improving air quality and occupant health [31].
- IV. Energy efficiency: designing energy-efficient ventilation systems is crucial for reducing operational costs and environmental impact. Factors such as fan selection, duct insulation, and control strategies can all contribute to improving energy efficiency [32].
- V. Noise control: MVSS can generate noise that may impact occupant comfort and productivity. Proper design considerations, such as selecting quiet equipment and incorporating sound attenuation measures, can help minimize noise levels [33].
- VI. Maintenance accessibility: easy access for maintenance and servicing is essential for ensuring the long-term performance and reliability of ventilation systems. Designing systems with accessible components and clear service pathways can facilitate routine maintenance tasks [34].
- VII. Integration with building controls: integration with building automation systems allows for better control and monitoring of ventilation systems. Designing systems that can communicate with other building systems can optimize performance and energy efficiency [35].
- VIII. Outdoor air quality: the quality of outdoor air intake can significantly impact the effectiveness of MVSS. Design considerations, such as locating intake vents away from sources of pollution and incorporating filtration, can help ensure the delivery of clean outdoor air [36].

The performance and effectiveness of MVSS in conventional engineering practice are influenced by a range of design factors that must be carefully considered. By following the aforementioned list of design factors, engineers can optimize the performance, energy efficiency, and indoor air quality of MVSS in buildings.

## 8 | Types of Mechanical Ventilation Systems in Conventional Engineering Practice

Several different types of MVSs are commonly used in the field, each with its own unique characteristics and advantages. These are highlighted as follows:

- I. Exhaust ventilation system: as shown in *Fig. 1*, this type of ventilation system works by removing stale air from a building and replacing it with fresh outdoor air. Exhaust fans are typically installed in key areas such as bathrooms, kitchens, and laundry rooms to remove moisture, odor and pollutants [37].

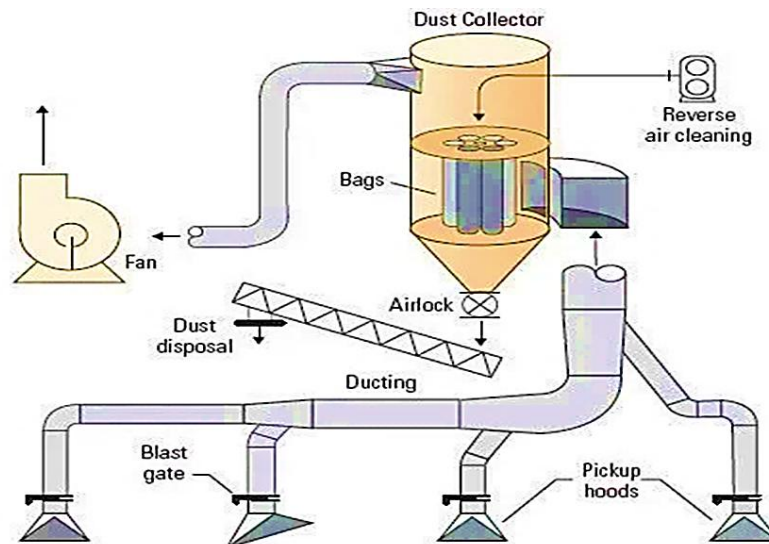

Fig. 1. Exhaust ventilation system [38].

- II. Supply ventilation system: In contrast to exhaust ventilation systems, supply ventilation systems work by bringing fresh outdoor air into a building while simultaneously exhausting stale indoor air, as shown in *Fig. 2*. This type of system is often used in buildings with tight envelopes to ensure adequate ventilation and indoor air quality [39].

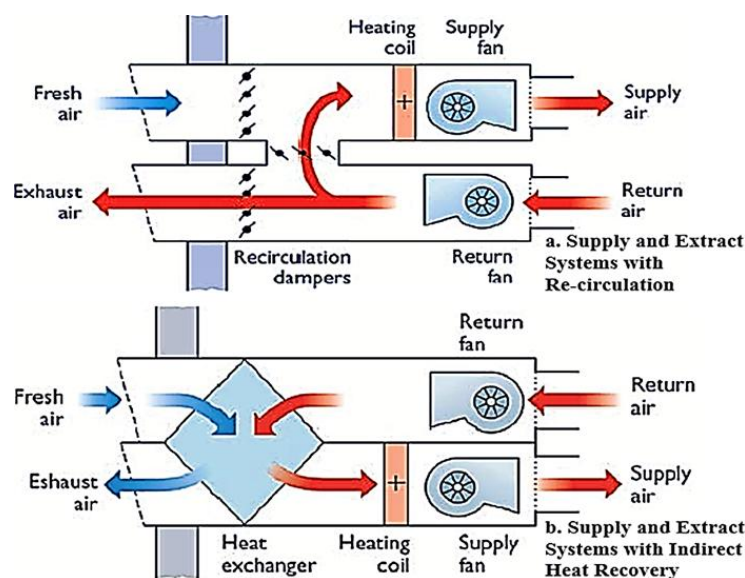
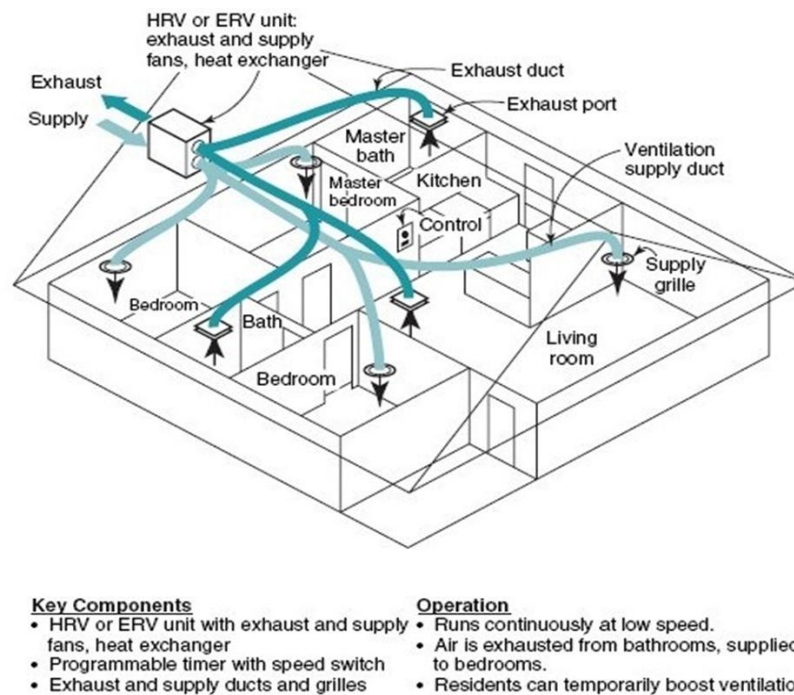

Fig. 2. Supply ventilation system [40].

III. Balanced ventilation system: as shown in *Fig. 3*, balanced ventilation systems combine elements of both exhaust and supply ventilation systems to provide a balanced flow of air into and out of a building. This type of system is designed to maintain a neutral pressure within the building, preventing the infiltration of outdoor pollutants and contaminants [41].



**Fig. 3. Balanced ventilation system [42].**

IV. Heat recovery ventilation system: Heat recovery ventilation systems, as shown in *Fig. 4*, are designed to recover heat from outgoing air and transfer it to incoming air, reducing energy consumption and improving indoor comfort. These systems are particularly effective in cold climates where heating costs are a concern [43].

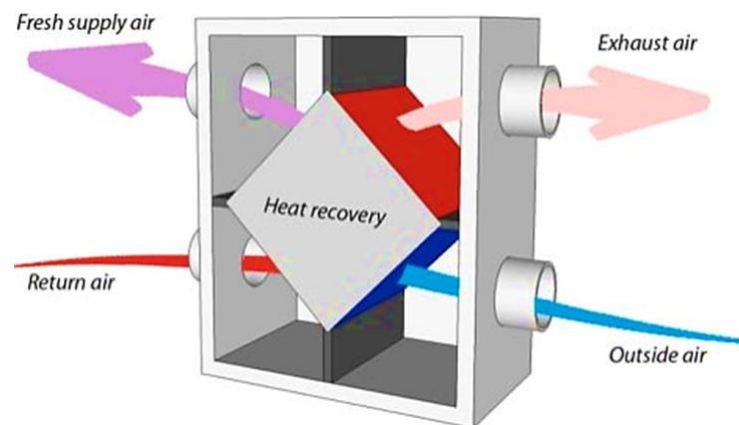

**Fig. 4. Heat recovery ventilation system [44].**

V. Energy recovery ventilation system: similar to heat recovery ventilation systems, energy recovery ventilation systems are designed to recover both heat and moisture from outgoing air and transfer it to incoming air, as shown in *Fig. 5*. This helps to maintain a comfortable indoor environment while reducing energy costs [45].

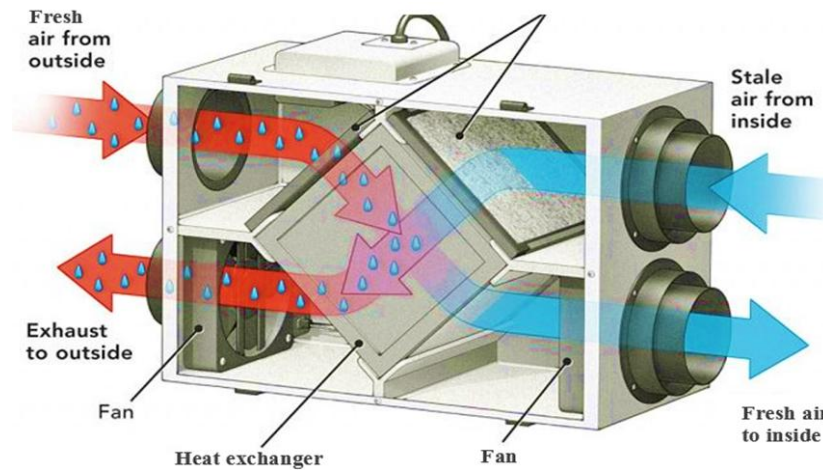

**Fig. 5. Energy recovery ventilation system [46].**

- VI. Demand-controlled ventilation system: demand-controlled ventilation systems use sensors to monitor indoor air quality and adjust ventilation rates accordingly. This type of system is highly efficient and can help to reduce energy consumption by only ventilating when necessary [47].
- VII. Natural ventilation system: natural ventilation systems rely on passive means such as windows, vents, and louvers to provide fresh air and remove stale air from a building. This type of system is cost-effective and environmentally friendly but may not be suitable for all climates or building types [48].

Several different types of MVSS are commonly used in conventional engineering practice, and the choice of system depends on factors such as building size, climate, and energy efficiency goals. By understanding the various types of MVSS available, engineers can design and implement effective ventilation solutions to ensure optimal indoor air quality and occupant comfort.

## 9 | Applications of Mechanical Ventilation Systems in Conventional Engineering Practice

MVSS are widely used in various engineering practices to provide fresh air, control indoor air quality, and maintain comfortable indoor environments. These systems are essential in a wide range of applications, from residential buildings to industrial facilities. Their applications include the following: Some of the primary applications of MVSS are:

- I. Heating, Ventilation and Air Conditioning (HVAC) systems for residential and commercial buildings: These systems help to regulate indoor air temperature, humidity, and air quality, providing a comfortable and healthy indoor environment for occupants. MVSS are also used in industrial facilities to control air quality, remove contaminants, and maintain safe working conditions for employees [49].
- II. Automotive industry: MVSS are used in vehicle cabins to provide fresh air and control temperature and humidity levels. These systems help to ensure the comfort and safety of passengers and drivers, especially in extreme weather conditions [50], [51].
- III. Aerospace industry: MVSS are essential for maintaining air quality and pressure in aircraft cabins. These systems help to provide a comfortable and safe environment for passengers and crew members during flights [52], [53].
- IV. Healthcare sector: MVSS are used in hospitals and medical facilities to control air quality, remove contaminants, and prevent the spread of infectious diseases. These systems are crucial for maintaining a sterile environment and protecting the health of patients and healthcare workers [54].
- V. Manufacturing industry: MVSS are used in production facilities to control air quality, remove pollutants, and maintain safe working conditions for employees. These systems help to prevent exposure to harmful chemicals and contaminants, ensuring the health and safety of workers [55].



Another important application of MVSs is in industrial facilities, where they are used to control airflow and temperature in manufacturing processes. These systems are essential for maintaining optimal conditions for equipment and processes, as well as for ensuring the safety and comfort of workers. MVSs play a crucial role in various engineering practices, providing fresh air, controlling indoor air quality, and maintaining comfortable indoor environments [56]. From residential buildings to industrial facilities, these systems are essential for ensuring the health, safety, and comfort of occupants.

## 10 | Advantages of Mechanical Ventilation Systems

There are several key advantages to using MVSs, which make them an essential component in modern building design. These include the following:

- I. Their ability to provide consistent and reliable air circulation throughout a building: This helps to maintain a comfortable and healthy indoor environment for occupants by ensuring that fresh air is constantly being brought in and stale air is being removed. This is especially important in buildings that are tightly sealed for energy efficiency, as natural ventilation may not be sufficient to provide adequate air exchange [57].
- II. Their ability to remove pollutants and contaminants from the indoor air: This is particularly important in buildings where there are sources of indoor air pollution, such as cooking fumes, cleaning chemicals, or off-gassing from building materials. By continuously circulating and filtering the air, MVSs can help to improve indoor air quality and create a healthier living or working environment [58].
- III. MVSs can also help to regulate indoor humidity levels. This is important for maintaining a comfortable and healthy indoor environment. High humidity levels can promote the growth of mold and mildew, while low humidity levels can cause discomfort and respiratory issues. By controlling the amount of moisture in the air, MVSs can help to prevent these problems and create a more pleasant indoor environment [59].

MVSs offer a range of benefits in conventional engineering practice, including improved air circulation, removal of pollutants, and regulation of indoor humidity levels. They can help to remove contaminants and fumes from industrial spaces, as well as to regulate temperature and humidity levels. In addition, these systems can help to prevent the build-up of harmful gases and vapors, reducing the risk of fire and explosion. These advantages make them an essential component in modern building design, helping to create a comfortable, healthy, and efficient indoor environment for occupants.

## 11 | Disadvantages of Mechanical Ventilation Systems

Despite their widespread use, MVSs come with the following key disadvantages that must be considered:

- I. Their high energy consumption: These systems require electricity to operate, leading to increased energy bills and a higher carbon footprint. In a world where sustainability and energy efficiency are becoming increasingly important, the high energy consumption of MVSs is a significant concern [60], [61].
- II. Their reliance on mechanical components, which can be prone to failure: Regular maintenance and repairs are necessary to ensure that these systems continue to function properly, adding to the overall cost of ownership. Additionally, MVSs can be noisy, creating a disruptive environment for building occupants [62].
- III. MVSs may not always be the most effective solution for improving indoor air quality: These systems simply circulate air within a building rather than actively removing pollutants and contaminants. As a result, indoor air quality may not be as high as desired, leading to potential health risks for occupants [63].

From high energy consumption and maintenance requirements to potential health risks for occupants, these systems may not always be the best choice for achieving optimal indoor air quality. As the field of engineering continues to evolve, it is important to consider alternative solutions that may offer more sustainable and effective ways to address indoor air quality concerns.

## 12 | Conclusion

The findings of this study on MVSS in conventional engineering practice have shed light on the importance of proper design and maintenance of these systems. Mechanical ventilation plays a crucial role in ensuring indoor air quality and occupant comfort in buildings. The study has highlighted the need for engineers to consider factors such as ventilation rates, air distribution, and filtration when designing MVSSs. It is essential to strike a balance between energy efficiency and indoor air quality to create a healthy and comfortable indoor environment. The study has also emphasized the significance of regular maintenance and monitoring of MVSSs to ensure optimal performance. Neglecting maintenance can lead to issues such as poor indoor air quality, increased energy consumption, and potential health risks for building occupants. By following these guidelines, engineers can contribute to creating healthier and more sustainable indoor environments for building occupants. Based on the findings from this study, the following recommendations are suggested to improve the design and operation of MVSSs:

- I. Undersized ventilation systems can lead to poor indoor air quality and discomfort for occupants. Therefore, it is important to conduct thorough calculations and assessments to determine the appropriate ventilation rates for different spaces within a building. Hence, it is recommended that the ventilation system be properly sized based on the occupancy and use of the building.
- II. The importance of cleaning filters, inspecting ductwork and checking for any obstructions or leaks in the system cannot be overemphasized. Neglecting the maintenance approach can lead to reduced efficiency, increased energy consumption, and potential health risks for occupants. Therefore, regular maintenance and servicing of ventilation systems are essential to ensure optimal performance.
- III. Incorporating features such as variable speed drives, heat recovery systems and demand-controlled ventilation can significantly improve the energy performance of MVSSs. Therefore, the use of energy-efficient ventilation systems should be considered to reduce energy consumption and operating costs.
- IV. The impact of poor indoor air quality on occupant health, productivity and overall well-being can be disastrous. Therefore, it is crucial to implement strategies such as using high-efficiency filters, controlling humidity levels, and minimizing the introduction of outdoor pollutants into the building.

By following these recommendations, engineers and building owners can ensure that ventilation systems perform effectively and contribute to a healthy and comfortable indoor environment for occupants.

## Author Contributions

Aniekan Essienubong Ikpe, Imoh Ime Ekanem, and Victor Etok Udoh contributed equally to this study. Aniekan Essienubong Ikpe conceptualized the research framework and drafted the manuscript. Imoh Ime Ekanem conducted a detailed analysis of contemporary engineering practices and the integration of mechanical ventilation systems. Victor Etok Udoh provided expertise in system design and applications, contributing to the interpretation of findings and manuscript revisions. All authors reviewed and approved the final manuscript for submission.

## Funding

This research did not receive any external funding and was supported by the authors' affiliated institutions.

## Data Availability

All relevant data supporting this study's findings are included in the manuscript. Additional information can be made available upon request from the corresponding author.

## Conflicts of Interest

The authors declare no conflicts of interest in relation to this research or its publication.

## References

- [1] Spengler, J. D., & Chen, Q. (2000). Indoor air quality factors in designing a healthy building. *Annual review of energy and the environment*, 25(1), 567–600. <https://doi.org/10.1146/annurev.energy.25.1.567>
- [2] Izadyar, N., & Miller, W. (2022). Ventilation strategies and design impacts on indoor airborne transmission: A review. *Building and environment*, 218, 109158. <https://doi.org/10.1016/j.buildenv.2022.109158>
- [3] Kubba, S. (2010). Indoor environmental quality. *LEED practices, certification, and accreditation handbook*, 211. <https://doi.org/10.1016/B978-1-85617-691-0.00007-2>
- [4] Mata, T. M., Martins, A. A., Calheiros, C. S. C., Villanueva, F., Alonso-Cuevilla, N. P., Gabriel, M. F., & Silva, G. V. (2022). Indoor air quality: A review of cleaning technologies. *Environments*, 9(9), 118. <https://doi.org/10.3390/environments9090118>
- [5] Schieweck, A., Uhde, E., Salthammer, T., Salthammer, L. C., Morawska, L., Mazaheri, M., & Kumar, P. (2018). Smart homes and the control of indoor air quality. *Renewable and sustainable energy reviews*, 94, 705–718. <https://doi.org/10.1016/j.rser.2018.05.057>
- [6] Yang, B., Melikov, A. K., Kabanshi, A., Zhang, C., Bauman, F. S., Cao, G., & Lin, Z. (2019). A review of advanced air distribution methods-theory, practice, limitations and solutions. *Energy and buildings*, 202, 109359. <https://doi.org/10.1016/j.enbuild.2019.109359>
- [7] Chenari, B., Carrilho, J. D., & Da Silva, M. G. (2016). Towards sustainable, energy-efficient and healthy ventilation strategies in buildings: A review. *Renewable and sustainable energy reviews*, 59, 1426–1447. <https://doi.org/10.1016/j.rser.2016.01.074>
- [8] Dong, B., Prakash, V., Feng, F., & O'Neill, Z. (2019). A review of smart building sensing system for better indoor environment control. *Energy and buildings*, 199, 29–46. <https://doi.org/10.1016/j.enbuild.2019.06.025>
- [9] Jouhara, H., Khordehgah, N., Almahmoud, S., Delpech, B., Chauhan, A., & Tassou, S. A. (2018). Waste heat recovery technologies and applications. *Thermal science and engineering progress*, 6, 268–289. <https://doi.org/10.1016/j.tsep.2018.04.017>
- [10] Aridi, R., Faraj, J., Ali, S., Gad El-Rab, M., Lemenand, T., & Khaled, M. (2021). Energy recovery in air conditioning systems: comprehensive review, classifications, critical analysis, and potential recommendations. *Energies*, 14(18), 5869. <https://doi.org/10.3390/en14185869>
- [11] Saber, E. M., Chaer, I., Gillich, A., & Ekpeti, B. G. (2021). Review of intelligent control systems for natural ventilation as passive cooling strategy for UK buildings and similar climatic conditions. *Energies*, 14(15), 4388. <https://doi.org/10.3390/en14154388>
- [12] Zaniboni, L., & Albatici, R. (2022). Natural and mechanical ventilation concepts for indoor comfort and well-being with a sustainable design perspective: A systematic review. *Buildings*, 12(11), 1983. <https://doi.org/10.3390/buildings12111983>
- [13] Hati, A. S. (2021). A comprehensive review of energy-efficiency of ventilation system using Artificial Intelligence. *Renewable and sustainable energy reviews*, 146, 111153. <https://doi.org/10.1016/j.rser.2021.111153>
- [14] Marques, G., Saini, J., Dutta, M., Singh, P. K., & Hong, W. C. (2020). Indoor air quality monitoring systems for enhanced living environments: A review toward sustainable smart cities. *Sustainability*, 12(10), 4024. <https://doi.org/10.3390/su12104024>
- [15] Liu, Z., Wang, G., Zhao, L., & Yang, G. (2021). Multi-points indoor air quality monitoring based on internet of things. *IEEE access*, 9, 70479–70492. <https://doi.org/10.1109/ACCESS.2021.3073681>
- [16] Meng, X., Yan, L., & Liu, F. (2022). A new method to improve indoor environment: combining the living wall with air-conditioning. *Building and environment*, 216, 108981. <https://doi.org/10.1016/j.buildenv.2022.108981>
- [17] Okochi, G. S., & Yao, Y. (2016). A review of recent developments and technological advancements of variable-air-volume (VAV) air-conditioning systems. *Renewable and sustainable energy reviews*, 59, 784–817. <https://doi.org/10.1016/j.rser.2015.12.328>

- [18] Russell, M., Sherman, M., & Rudd, A. (2007). Review of residential ventilation technologies. *Hvac & R research*, 13(2), 325–348. <https://doi.org/10.1080/10789669.2007.10390957>
- [19] Sha, H., & Qi, D. (2020). Investigation of mechanical ventilation for cooling in high-rise buildings. *Energy and buildings*, 228, 110440. <https://doi.org/10.1016/j.enbuild.2020.110440>
- [20] Saran, S., Gurjar, M., Baronia, A., Sivapurapu, V., Ghosh, P. S., Raju, G. M., & Maurya, I. (2020). Heating, ventilation and air conditioning (HVAC) in intensive care unit. *Critical care*, 24, 1–11. <https://doi.org/10.1186/s13054-020-02907-5>
- [21] Seuntjens, O., Belmans, B., Buyle, M., & Audenaert, A. (2022). A critical review on the adaptability of ventilation systems: current problems, solutions and opportunities. *Building and environment*, 212, 108816. <https://doi.org/10.1016/j.buildenv.2022.108816>
- [22] Evola, G., Gagliano, A., Marletta, L., & Nocera, F. (2017). Controlled mechanical ventilation systems in residential buildings: primary energy balances and financial issues. *Journal of building engineering*, 11, 96–107. <https://doi.org/10.1016/j.jobe.2017.04.010>
- [23] Emmerich, S. J., Dols, W. S., & Axley, J. W. (2001). *Natural ventilation review and plan for design and analysis tools*. National Institute of Standards and Technology. <https://nvlpubs.nist.gov/nistpubs/Legacy/IR/nistir6781>
- [24] Persily, A. (2006). What we think we know about ventilation. *International journal of ventilation*, 5(3), 275–290. <https://doi.org/10.1080/14733315.2006.11683745>
- [25] Alizadeh, M., & Sadrameli, S. M. (2016). Development of free cooling based ventilation technology for buildings: thermal energy storage (TES) unit, performance enhancement techniques and design considerations-A review. *Renewable and sustainable energy reviews*, 58, 619–645. <https://doi.org/10.1016/j.rser.2015.12.168>
- [26] Harvie, J. (2014). Problems in residential design for ventilation and noise part 2: mechanical ventilation. *Acoustics bulletin*, 33. [https://www.researchgate.net/profile/Jack-Harvie-Clark/publication/286558096\\_Problems\\_in\\_residential\\_design\\_for\\_ventilation\\_and\\_noise/links/5914333a0f7e9b70f49a1a56/Problems-in-residential-design-for-ventilation-and-noise.pdf](https://www.researchgate.net/profile/Jack-Harvie-Clark/publication/286558096_Problems_in_residential_design_for_ventilation_and_noise/links/5914333a0f7e9b70f49a1a56/Problems-in-residential-design-for-ventilation-and-noise.pdf)
- [27] Alyazji, Q., & Asiksoy, G. (2021). Evaluating mechanical ventilators using multi criteria decision making techniques. *International journal of online & biomedical engineering*, 17(7). <https://doi.org/10.3991/ijoe.v17i07.21769>
- [28] Keszler, M. (2009). State of the art in conventional mechanical ventilation. *Journal of perinatology*, 29(4), 262–275. <https://doi.org/10.1038/jp.2009.11>
- [29] Branson, R. D., Johannigman, J. A., Daugherty, E. L., & Rubinson, L. (2008). Surge capacity mechanical ventilation. *Respiratory care*, 53(1), 78–90. <https://rc.rcjournal.com/content/respcare/53/1/78.full>
- [30] Tomasi, R., Krajčík, M., Simone, A., & Olesen, B. W. (2013). Experimental evaluation of air distribution in mechanically ventilated residential rooms: Thermal comfort and ventilation effectiveness. *Energy and buildings*, 60, 28–37. <https://doi.org/10.1016/j.enbuild.2013.01.003>
- [31] Quang, T. N., He, C., Morawska, L., & Knibbs, L. D. (2013). Influence of ventilation and filtration on indoor particle concentrations in urban office buildings. *Atmospheric environment*, 79, 41–52. <https://doi.org/10.1016/j.atmosenv.2013.06.009>
- [32] Giama, E. (2021). Review on ventilation systems for building applications in terms of energy efficiency and environmental impact assessment. *Energies*, 15(1), 98. <https://doi.org/10.3390/en15010098>
- [33] Trematerra, A., Bevilacqua, A., & Iannace, G. (2023). Noise control in air mechanical ventilation systems with three-dimensional metamaterials. *Applied sciences*, 13(3), 1650. <https://doi.org/10.3390/app13031650>
- [34] Atakul, N., & Ergonul, S. (2022). Exploring architectural design factors affecting building maintainability and strategies to overcome current shortcomings. *Journal of performance of constructed facilities*, 36(6), 4022053. [https://doi.org/10.1061/\(ASCE\)CF.1943-5509.0001770](https://doi.org/10.1061/(ASCE)CF.1943-5509.0001770)
- [35] Omer, A. M. (2014). Principle of low energy building design: heating, ventilation and air conditioning. *International journal of energy, environment and economics*, 22(3), 187.
- [36] Chen, J., Brager, G. S., Augenbroe, G., & Song, X. (2019). Impact of outdoor air quality on the natural ventilation usage of commercial buildings in the US. *Applied energy*, 235, 673–684. <https://doi.org/10.1016/j.apenergy.2018.11.020>

- [37] Cao, Z., Wang, Y., Duan, M., & Zhu, H. (2017). Study of the vortex principle for improving the efficiency of an exhaust ventilation system. *Energy and buildings*, 142, 39–48. <https://doi.org/10.1016/j.enbuild.2017.03.007>
- [38] Moradpour, Z., Taghavi, S. H., Hesam, G., Atamaleki, A., & Garkaz, A. (2020). Investigation of dust chemical compounds emitted by electric arc furnace (EAF) with a reuse perspective. *Iranian journal of health, safety and environment*, 7(1), 1408–1412.
- [39] Litvinova, N. A. (2017). Supply ventilation and prevention of carbon monoxide (II) ingress into building premises. *IOP conference series: materials science and engineering* (pp. 12087). IOP publishing Ltd. DOI: 10.1088/1757-899X/262/1/012087
- [40] Koller, C., Talmon-Gros, M. J., Junge, R., & Schuetze, T. (2017). Energy toolbox – Framework for the development of a tool for the primary design of zero emission buildings in European and Asian cities. *Sustainability*, 9(12), 2244. <https://doi.org/10.3390/su9122244>
- [41] Gaczoł, T. (2018). Living quarters. a natural balanced ventilation system. simulations part 1. *E3S web of conferences* (pp. 25). EDP Sciences. <https://doi.org/10.1051/e3sconf/20184900025>
- [42] Bliss, S. (2006). *Best practices guide to residential construction: materials*. Wiley.
- [43] El Fouih, Y., Stabat, P., Rivière, P., Hoang, P., & Archambault, V. (2012). Adequacy of air-to-air heat recovery ventilation system applied in low energy buildings. *Energy and buildings*, 54, 29–39. <https://doi.org/10.1016/j.enbuild.2012.08.008>
- [44] Mardiana-Idayu, A., & Riffat, S. B. (2012). Review on heat recovery technologies for building applications. *Renewable and sustainable energy reviews*, 16(2), 1241–1255. <https://doi.org/10.1016/j.rser.2011.09.026>
- [45] Jaber, S., & Ezzat, A. W. (2017). Investigation of energy recovery with exhaust air evaporative cooling in ventilation system. *Energy and buildings*, 139, 439–448. <https://doi.org/10.1016/j.enbuild.2017.01.019>
- [46] Picallo-Perez, A., Sala-Lizarraga, J. M., Odriozola-Maritorena, M., Hidalgo-Betanzos, J. M., & Gomez-Arriaran, I. (2021). Ventilation of buildings with heat recovery systems: Thorough energy and exergy analysis for indoor thermal wellness. *Journal of building engineering*, 39, 102255. <https://doi.org/10.1016/j.job.2021.102255>
- [47] Fisk, W. J., & De Almeida, A. T. (1998). Sensor-based demand-controlled ventilation: a review. *Energy and buildings*, 29(1), 35–45. [https://doi.org/10.1016/S0378-7788\(98\)00029-2](https://doi.org/10.1016/S0378-7788(98)00029-2)
- [48] Ghiaus, C., & Allard, F. (2012). The physics of natural ventilation. In *Natural ventilation in the urban environment* (pp. 36–80). Routledge.
- [49] Krarti, M. (2008). Energy efficient systems and strategies for heating, ventilating, and air conditioning (HVAC) of buildings. *Journal of green building*, 3(1), 44–55. <https://doi.org/10.3992/jgb.3.1.44>
- [50] Xu, B., Chen, X., & Xiong, J. (2018). Air quality inside motor vehicles' cabins: A review. *Indoor and built environment*, 27(4), 452–465. <https://doi.org/10.1177/1420326X16679217>
- [51] Sulaiman, S. A., & Zali, K. A. M. (2022). The importance of ventilation in vehicle cabin on air quality. *Energy and environment in the tropics* (pp. 305–326). Springer. [https://doi.org/10.1007/978-981-19-6688-0\\_19](https://doi.org/10.1007/978-981-19-6688-0_19)
- [52] Farag, A. M., & Khalil, E. E. (2015). Numerical analysis and optimization of different ventilation systems for commercial aircraft cabins. *2015 IEEE aerospace conference* (pp. 1–12). IEEE. DOI: 10.1109/AERO.2015.7119230
- [53] Elmaghraby, H. A., Chiang, Y. W., & Aliabadi, A. A. (2018). Ventilation strategies and air quality management in passenger aircraft cabins: A review of experimental approaches and numerical simulations. *Science and technology for the built environment*, 24(2), 160–175. <https://doi.org/10.1080/23744731.2017.1387463>
- [54] Baudet, A., Baurès, E., Guegan, H., Blanchard, O., Guillaso, M., Le Cann, P., & Florentin, A. (2021). Indoor air quality in healthcare and care facilities: chemical pollutants and microbiological contaminants. *Atmosphere*, 12(10), 1337. <https://doi.org/10.3390/atmos12101337>
- [55] Jafari, M. J., Karimi, A., & Azari, M. R. (2008). The role of exhaust ventilation systems in reducing occupational exposure to organic solvents in a paint manufacturing factory. *Indian journal of occupational and environmental medicine*, 12(2), 82–87. DOI:10.4103/0019-5278.43266

- [56] Parvin, F., Islam, S., Akm, S. I., Urmy, Z., & Ahmed, S. (2020). A study on the solutions of environment pollutions and worker's health problems caused by textile manufacturing operations. *Biomedical journal science technic research*, 28(4), 21831–21844. <http://dx.doi.org/10.26717/BJSTR.2020.28.004692>
- [57] Gattinoni, L., Marini, J. J., Collino, F., Maiolo, G., Rapetti, F., Tonetti, T., & Quintel, M. (2017). The future of mechanical ventilation: lessons from the present and the past. *Critical care*, 21, 1–11. <https://doi.org/10.1186/s13054-017-1750-x>
- [58] Myers, T. R., & Macintyre, N. R. (2007). Does airway pressure release ventilation offer important new advantages in mechanical ventilator support? *Respiratory care*, 52(4), 452–460.
- [59] Tol, G., & Palmer, J. (2010). Principles of mechanical ventilation. *Anaesthesia & intensive care medicine*, 11(4), 125–128. <https://doi.org/10.1016/j.mpaic.2010.01.002>
- [60] Willatts, S. M. (1985). Alternative modes of ventilation: Part I. Disadvantages of controlled mechanical ventilation: intermittent mandatory ventilation. *Intensive care medicine*, 11, 51–55. <https://doi.org/10.1007/BF00254773>
- [61] Maier, T., Krzaczek, M., & Tejchman, J. (2009). Comparison of physical performances of the ventilation systems in low-energy residential houses. *Energy and buildings*, 41(3), 337–353. <https://doi.org/10.1016/j.enbuild.2008.10.007>
- [62] Cox, C. E., Martinu, T., Sathy, S. J., Clay, A. S., Chia, J., Gray, A. L., & Tulskey, J. A. (2009). Expectations and outcomes of prolonged mechanical ventilation. *Critical care medicine*, 37(11), 2888–2894. DOI:10.1097/CCM.0b013e3181ab86ed
- [63] Jones, A. P. (1999). Indoor air quality and health. *Atmospheric environment*, 33(28), 4535–4564. [https://doi.org/10.1016/S1352-2310\(99\)00272-1](https://doi.org/10.1016/S1352-2310(99)00272-1)